

Dübel / Muffen für VB 35/35 M, VB 36/36 M, VB 135 Bohr-ø 5, 6, 8 und 10 mm

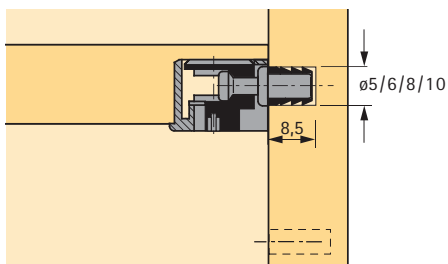

Einschraubdübel DU 426



- Gewinde M4 x 7,8 mm
- Spannmaß 6,7 mm
- Stahl blank

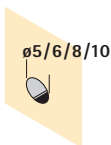

Bestell-Nr.	VE
0 065 370	1/200

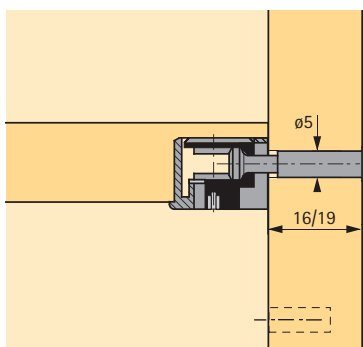
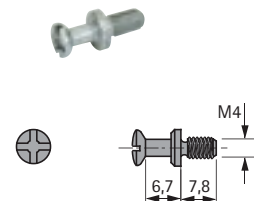

Enddübel DU 981/DU 982



- Für 16/19 mm Seitenwand
- Bohr-ø 5 mm
- Spannmaß 22,8 mm/25,8 mm
- Stahl vernickelt

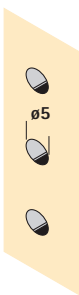

Artikel	Seitenwand mm	Bestell-Nr.	VE
DU 981	16	0 079 651	1/200
DU 982	19	0 079 653	1/200

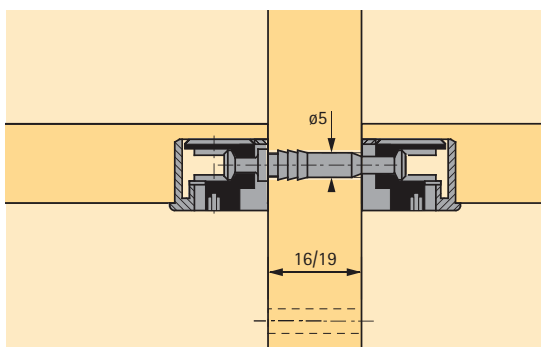
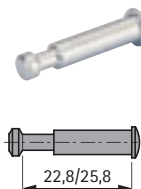

Doppeldübel DU 712/DU 867



- Für 16/19 mm Mittelwand
- Bohr-ø 5 mm
- Spannmaß 6,7 mm
- Stahl blank

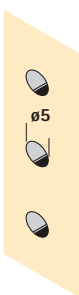

Artikel	Mittelwand mm	Bestell-Nr.	VE
DU 712	16	0 065 535	1/100
DU 867	19	0 065 536	1/100

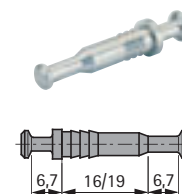

DU 426 ist einsetzbar mit ...

Spreizmuffe

- Für Gewinde M4
- Bohr-ø 5 oder 6 mm
- Messing blank

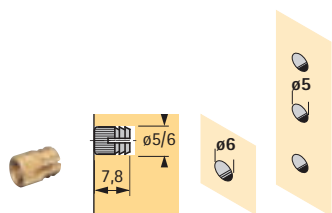

Bohr-ø mm	Bestell-Nr.	VE
5	0 048 578	1/200
6	0 065 541	1/200

Muffe Nr. 30

- Für Gewinde M4
- Bohr-ø 8 mm
- Kunststoff weiß

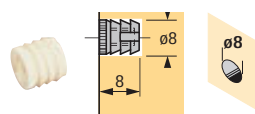

Bestell-Nr.	VE
0 079 529	1/200

Muffe Nr. 74

- Für Gewinde M4
- Bohr-ø 10 mm
- Kunststoff weiß

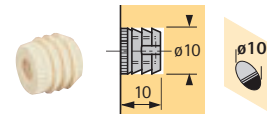

Bestell-Nr.	VE
0 079 530	1/200

Endschraube

- Für Gewinde M4
- Einsetzbar mit Gewindehülse M4*
- Stahl vernickelt

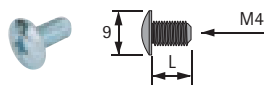

Länge L mm	Bestell-Nr.	VE
8	0 079 525	200
9	0 079 527	200

* Gewindehülse

- Für Gewinde M4
- Bohr-ø 5 mm
- Stahl chromatiert

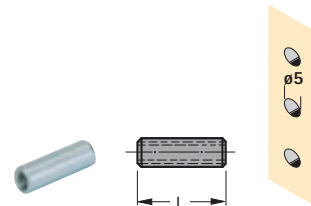

Länge L mm	Bestell-Nr.	VE
15	0 063 016	1/200
18	0 064 908	1/200
22	0 063 017	1/200

Bohrlehre Accura 32 für System 32 und Dübelbohrungen – siehe Gruppe 2